

“JUST THE MATHS”

UNIT NUMBER

5.6

GEOMETRY 6

(Conic sections - the parabola)

by

A.J.Hobson

<p>5.6.1 Introduction (the standard parabola) 5.6.2 Other forms of the equation of a parabola 5.6.3 Exercises 5.6.4 Answers to exercises</p>
--

UNIT 5.6 - GEOMETRY 6

CONIC SECTIONS - THE PARABOLA

5.5.1 INTRODUCTION

The Standard Form for the equation of a Parabola

DEFINITION

A parabola is the path traced out by (or “**locus**” of) a point, P, whose distance, SP, from a fixed point, S, called the “**focus**”, is equal to its perpendicular distance, PM, from a fixed line, l , called the “**directrix**”.

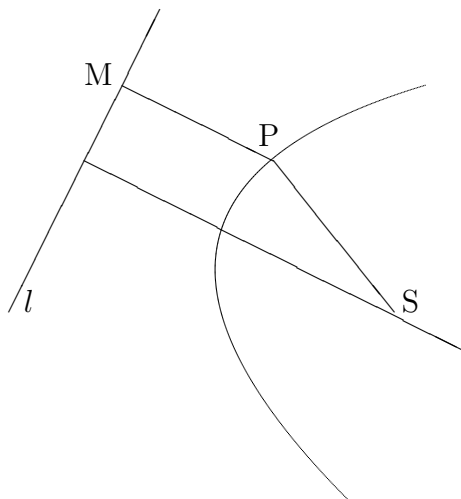

For convenience, we may take the directrix, l , to be a vertical line - with the perpendicular line - with the focus, S, being the x -axis. We could take the y -axis to be the directrix itself, but the equation of the parabola turns out to be simpler if we use a different line; namely the line parallel to the directrix passing through the mid-point of the perpendicular from the focus onto the directrix. This point is one of the points on the parabola so that we make the curve pass through the origin.

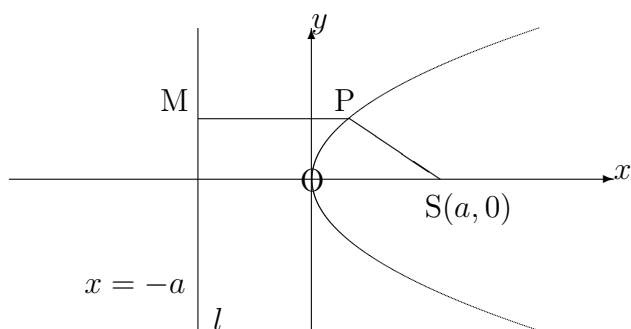

Letting the focus be the point $(a, 0)$ (since it lies on the x -axis) the definition of the parabola implies that $SP = PM$. That is,

$$\sqrt{(x - a)^2 + y^2} = x + a.$$

Squaring both sides gives

$$(x - a)^2 + y^2 = x^2 + 2ax + a^2,$$

or

$$x^2 - 2ax + a^2 + y^2 = x^2 + 2ax + a^2.$$

This reduces to

$$y^2 = 4ax$$

and is the standard equation of a parabola with “**vertex**” at the origin, focus at $(a, 0)$ and axis of symmetry along the x -axis. All other versions of the equation of a parabola which we shall consider will be based on this version.

Notes:

(i) If a is negative, the bowl of the parabola faces in the opposite direction towards negative x values.

(ii) Any equation of the form $y^2 = kx$, where k is a constant, represents a parabola with vertex at the origin and axis of symmetry along the x -axis. Its focus will lie at the point $(\frac{k}{4}, 0)$; it is worth noting this observation for future reference.

(iii) The parabola $y^2 = 4ax$ may be represented parametrically by the pair of equations

$$x = at^2, \quad y = 2at;$$

but the parameter, t , has no significance in the diagram such as was the case for the circle.

5.6.2 OTHER FORMS OF THE EQUATION OF A PARABOLA

(a) **Vertex at $(0, 0)$ with focus at $(0, a)$**

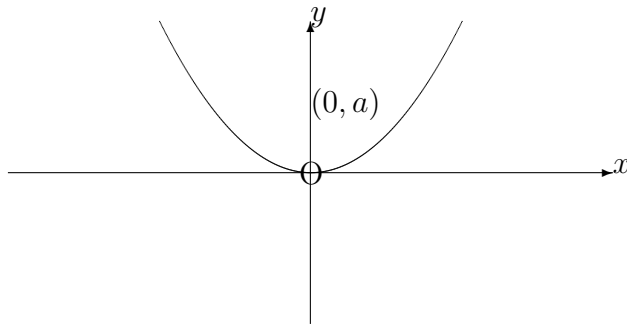

This parabola is effectively the same as the standard one except that the roles of x and y have been reversed. We may assume, therefore that the curve has equation

$$x^2 = 4ay$$

with associated parametric equations

$$x = 2at, \quad y = at^2$$

(b) **Vertex at (h, k) with focus at $(h + a, k)$**

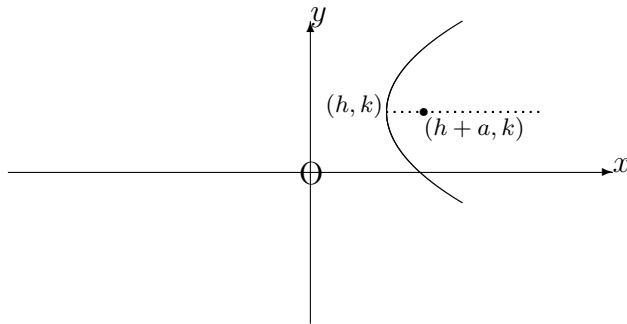

If we were to consider a temporary change of origin to the point (h, k) , with X -axis and Y -axis, the parabola would have equation

$$Y^2 = 4aX.$$

With reference to the original axes, therefore, the parabola has equation

$$(y - k)^2 = 4a(x - h).$$

Notes:

(i) Such a parabola will often be encountered in the expanded form of this equation, containing quadratic terms in y and linear terms in x . Conversion to the stated form by completing the square in the y terms will make it possible to identify the vertex and focus.

(ii) With reference to the new axes with origin at the point (h, k) , the parametric equations of the parabola would be

$$X = at^2, \quad Y = 2at.$$

Hence, with reference to the original axes, the parametric equations are

$$x = h + at^2, \quad y = k + 2at.$$

(c) Vertex at (h, k) with focus at $(h, k + a)$

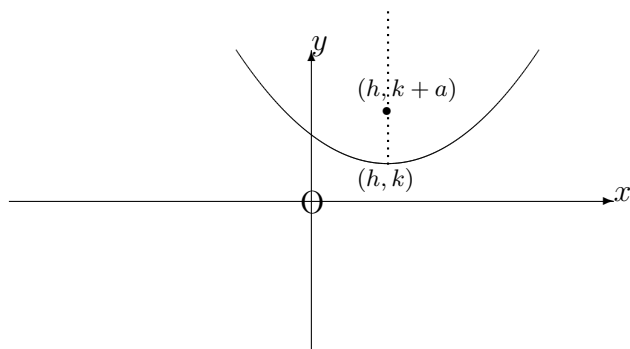

If we were to consider a temporary change of origin to the point (h, k) with X -axis and Y -axis, the parabola would have equation

$$X^2 = 4aY.$$

With reference to the original axes, therefore, the parabola has equation

$$(x - h)^2 = 4a(y - k).$$

Notes:

(i) Such a parabola will often be encountered in the expanded form of this equation, containing quadratic terms in x and linear terms in y . Conversion to the stated form by completing the square in the x terms will make it possible to identify the vertex and focus.

(ii) With reference to the new axes with origin at the point (h, k) , the parametric equations of the parabola would be

$$X = 2at, \quad Y = at^2.$$

Hence, with reference to the original axes, the parametric equations are

$$x = h + 2at, \quad y = k + at^2.$$

EXAMPLES

1. Give a sketch of the parabola whose cartesian equation is

$$y^2 - 6y + 3x = 10,$$

showing the co-ordinates of the vertex, focus and intesections with the x -axis and y -axis.

Solution

First, we must complete the square in the y terms obtaining

$$y^2 - 6y \equiv (y - 3)^2 - 9.$$

Hence, the equation becomes

$$(y - 3)^2 - 9 + 3x = 10.$$

That is,

$$(y - 3)^2 = 19 - 3x,$$

or

$$(y - 3)^2 = 4 \cdot \left(-\frac{3}{4}\right) \left(x - \frac{19}{3}\right).$$

Thus, the vertex lies at the point $\left(\frac{19}{3}, 3\right)$ and the focus lies at the point $\left(\frac{19}{3} - \frac{3}{4}, 3\right)$; that is, $\left(\frac{67}{12}, 3\right)$.

The parabola intersects the x -axis where $y = 0$, i.e.

$$3x = 10,$$

giving $x = \frac{10}{3}$.

The parabola intersects the y -axis where $x = 0$; that is,

$$y^2 - 6y - 10 = 0,$$

which is a quadratic equation with solutions

$$y = \frac{6 \pm \sqrt{36 + 40}}{2} \cong 7.36 \text{ or } -1.36$$

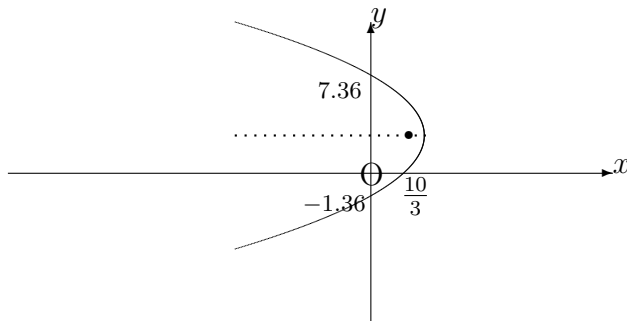

2. Use the parametric equations of the parabola

$$x^2 = 8y$$

to determine its points of intersection with the straight line

$$y = x + 6.$$

Solution

The parametric equations are $x = 4t$, $y = 2t^2$.

Substituting these into the equation of the straight line, we have

$$2t^2 = 4t + 6.$$

That is,

$$t^2 - 2t - 3 = 0,$$

or

$$(t - 3)(t + 1) = 0,$$

which is a quadratic equation in t having solutions $t = 3$ and $t = -1$.

The points of intersection are therefore $(12, 18)$ and $(-4, 2)$.

5.6.3 EXERCISES

1. For the following parabolae, determine the co-ordinates of the vertex, the focus and the points of intersection with the x -axis and y -axis where appropriate:

(a)

$$(y - 1)^2 = 4(x - 2);$$

(b)

$$(x + 1)^2 = 8(y - 3);$$

(c)

$$2x = y^2 + 4y + 6;$$

(d)

$$x^2 + 4x - 4y + 6 = 0.$$

2. Use the parametric equations of the parabola

$$y^2 = 12x$$

to determine its points of intersection with the straight line

$$6x + 5y - 12 = 0.$$

5.6.4 ANSWERS TO EXERCISES

1. (a) Vertex $(2, 1)$, Focus $(3, 1)$, Intersection $(\frac{9}{4}, 0)$ with the x -axis;
(b) Vertex $(-1, 3)$, Focus $(-1, 5)$, Intersection $(0, \frac{25}{8})$ with the y -axis;
(c) Vertex $(1, -2)$, Focus $(\frac{3}{2}, -2)$, Intersection $(3, 0)$ with the x -axis;
(d) Vertex $(-2, \frac{1}{2})$, Focus $(-2, \frac{3}{2})$, Intersection $(0, \frac{3}{2})$ with the y -axis.
2. $x = 3t^2$ and $y = 6t$ give $18t^2 + 30t - 12 = 0$ with solutions $t = \frac{1}{3}$ and $t = -2$. Hence the points of intersection are $(\frac{1}{3}, 2)$ and $(12, -12)$.