

“JUST THE MATHS”

UNIT NUMBER

5.11

GEOMETRY 11
(Polar curves)

by

A.J.Hobson

<p>5.11.1 Introduction</p> <p>5.11.2 The use of polar graph paper</p> <p>5.11.3 Exercises</p> <p>5.11.4 Answers to exercises</p>
--

UNIT 5.11 - GEOMETRY 11 - POLAR CURVES

5.11.1 INTRODUCTION

The concept of polar co-ordinates was introduced in Unit 5.1 as an alternative method, to cartesian co-ordinates, of specifying the position of a point in a plane. It was also seen that a relationship between cartesian co-ordinates, x and y , may be converted into an equivalent relationship between polar co-ordinates, r and θ by means of the formulae,

$$x = r \cos \theta, \quad \text{and} \quad y = r \sin \theta,$$

while the reverse process may be carried out using the formulae

$$r^2 = x^2 + y^2 \quad \text{and} \quad \theta = \tan^{-1}(y/x).$$

Sometimes the reverse process may be simplified by using a mixture of both sets of formulae.

In this Unit, we shall consider the graphs of certain relationships between r and θ without necessarily referring to the equivalent of those relationships in cartesian co-ordinates. The graphs obtained will be called “**polar curves**”.

Note:

In Unit 5.1, no consideration was given to the possibility of **negative** values of r ; in fact, when polar co-ordinates are used in the subject of complex numbers (see Units 6.1 - 6.6) r is **not** allowed to take negative values.

However, for the present context it will be necessary to assign a meaning to a point (r, θ) , in polar co-ordinates, when r is negative.

We simply plot the point at a distance of $|r|$ along the $\theta - 180^\circ$ line; and, of course, this implies that, when r is negative, the point (r, θ) is the same as the point $(|r|, \theta - 180^\circ)$

5.11 2 THE USE OF POLAR GRAPH PAPER

For equations in which r is expressed in terms of θ , it is convenient to plot values of r against values of θ using a special kind of graph paper divided into small cells by concentric circles and radial lines.

The radial lines are usually spaced at intervals of 15° and the concentric circles allow a scale to be chosen by which to measure the distances, r , from the pole.

We illustrate with examples:

EXAMPLES

1. Sketch the graph of the equation

$$r = 2 \sin \theta.$$

Solution

First we construct a table of values of r and θ , in steps of 15° , from 0° to 360° .

θ	0°	15°	30°	45°	60°	75°	90°	105°	120°	135°	150°	165°	180°	195°
r	0	0.52	1	1.41	1.73	1.93	2	1.93	1.73	1.41	1	0.52	0	-0.52

θ	210°	225°	240°	255°	270°	285°	300°	315°	330°	345°	360°
r	-1	-1.41	-1.73	-1.93	-2	-1.93	-1.73	-1.41	-1	-0.52	0

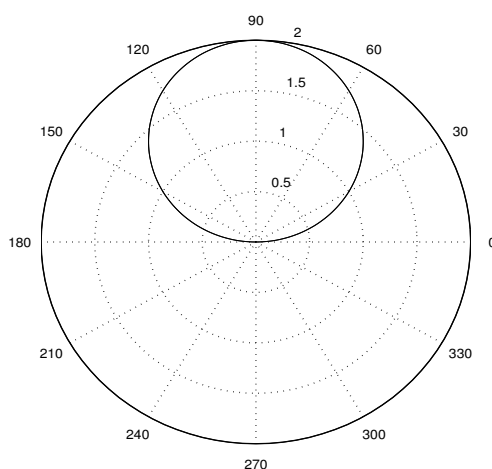

Notes:

- (i) The curve, in this case, is a circle whose cartesian equation turns out to be

$$x^2 + y^2 - 2y = 0.$$

- (ii) The fact that half of the values of r are negative means, here, that the circle is described twice over. For example, the point $(-0.52, 195^\circ)$ is the same as the point $(0.52, 15^\circ)$.

2. Sketch the graph of the following equations:

(a)

$$r = 2(1 + \cos \theta);$$

(b)

$$r = 1 + 2 \cos \theta;$$

(c)

$$r = 5 + 3 \cos \theta.$$

Solution

(a) The table of values is as follows:

θ	0°	15°	30°	45°	60°	75°	90°	105°	120°	135°	150°	165°	180°
r	4	3.93	3.73	3.42	3	2.52	2	1.48	1	0.59	0.27	0.07	0

θ	195°	210°	225°	240°	255°	270°	285°	300°	315°	330°	345°	360°
r	0.07	0.27	0.59	1	1.48	2	2.52	3	3.42	3.73	3.93	4

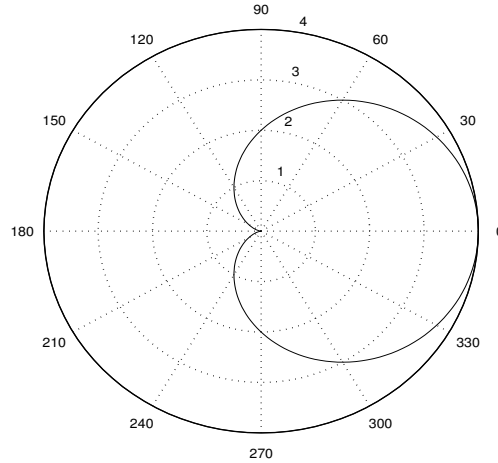

(b) The table of values is as follows:

θ	0°	15°	30°	45°	60°	75°	90°	105°	120°	135°	150°	165°	180°
r	3	2.93	2.73	2.41	2	1.52	1	0.48	0	-0.41	-0.73	-0.93	-1

θ	195°	210°	225°	240°	255°	270°	285°	300°	315°	330°	345°	360°
r	-0.93	-0.73	-0.41	0	0.48	1	1.52	2	2.41	2.73	2.93	3

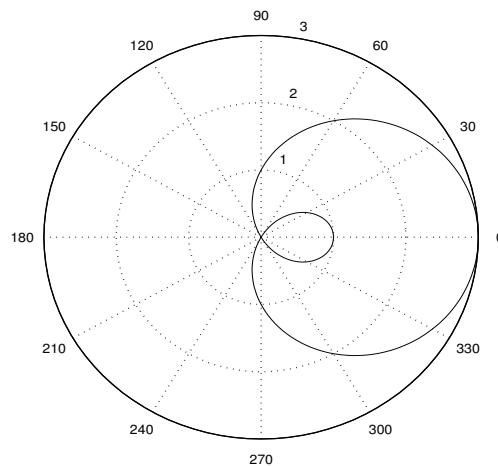

(c) The table of values is as follows:

θ	0°	15°	30°	45°	60°	75°	90°	105°	120°	135°	150°	165°	180°
r	8	7.90	7.60	7.12	6.5	5.78	5	4.22	3.5	2.88	2.40	2.10	2

θ	195°	210°	225°	240°	255°	270°	285°	300°	315°	330°	345°	360°
r	2.10	2.40	2.88	3.5	4.22	5	5.78	6.5	7.12	7.60	7.90	8

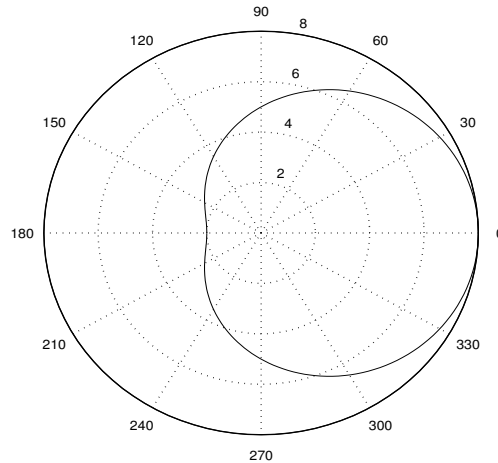

Note:

Each of the three curves in the above example is known as a “**limaçon**” and they illustrate special cases of the more general curve, $r = a + b \cos \theta$, as follows:

- (i) If $a = b$, the limaçon may also be called a “**cardioid**”; that is, a heart-shape. At the pole, the curve possesses a “**cusp**”.
- (ii) If $a < b$, the limaçon contains a “**re-entrant loop**”.
- (iii) If $a > b$, the limaçon contains neither a cusp nor a re-entrant loop.

Other well-known polar curves, together with any special titles associated with them, may be found in the answers to the exercises at the end of this unit.

5.11.3 EXERCISES

Plot the graphs of the following polar equations:

1.

$$r = 3 \cos \theta.$$

2.

$$r = \sin 3\theta.$$

3.

$$r = \sin 2\theta.$$

4.

$$r = 4 \cos 3\theta.$$

5.

$$r = 5 \cos 2\theta.$$

6.

$$r = 2\sin^2\theta.$$

7.

$$r = 2\cos^2\theta.$$

8.

$$r^2 = 25 \cos 2\theta.$$

9.

$$r^2 = 16 \sin 2\theta.$$

10.

$$r = 2\theta.$$

5.11.4 ANSWERS TO EXERCISES

1. The graph is as follows:

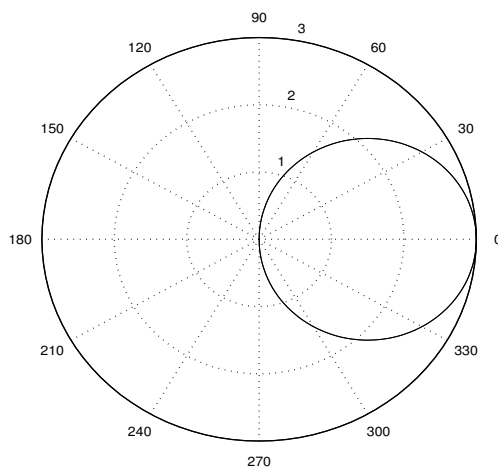

Note:

This is an example of the more general curve, $r = a \cos \theta$, which is a circle.

2. The graph is as follows:

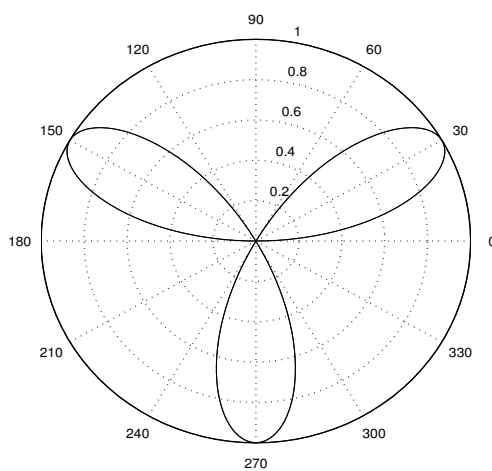

Note:

This is an example of the more general curve, $r = a \sin n\theta$, where n is **odd**. It is an “ n -leaved rose”.

3. The graph is as follows:

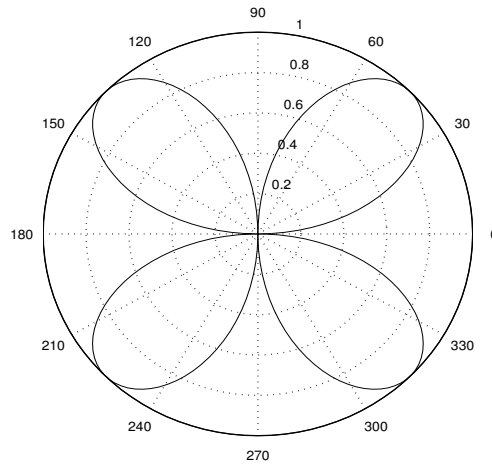

Note:

This is an example of the more general curve, $r = a \sin n\theta$, where n is **even**. It is a “ $2n$ -leaved rose”.

4. The graph is as follows:

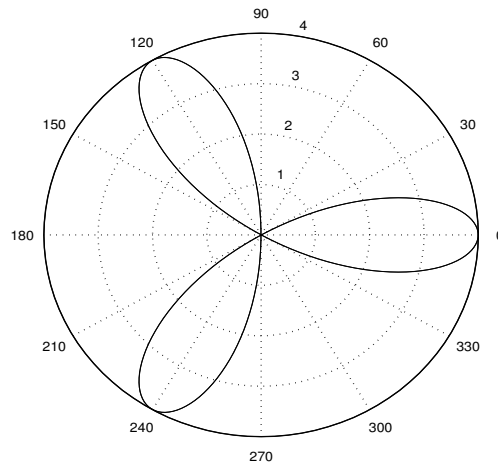

Note:

This is an example of the more general curve, $r = a \cos n\theta$, where n is **odd**. It is an “ n -leaved rose”.

5. The graph is as follows:

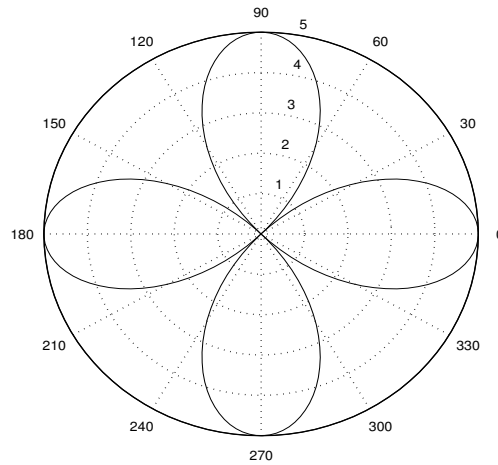

Note:

This is an example of the more general curve, $r = a \cos n\theta$, where n is **even**. It is a “ **$2n$ -leaved rose**”.

6. The graph is as follows:

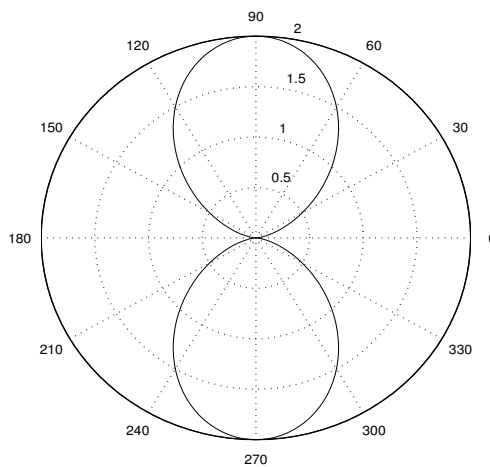

Note:

This is an example of the more general curve, $r = a \sin^2\theta$, which is called a “**lemniscate**”.

7. The graph is as follows:

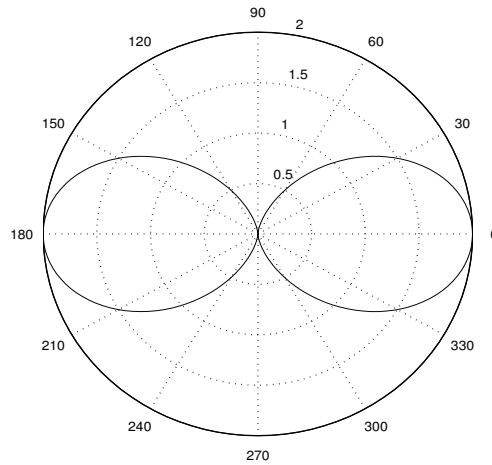

Note:

This is an example of the more general curve, $r = a \cos^2 \theta$, which is also called a “**lemniscate**”.

8. The graph is as follows:

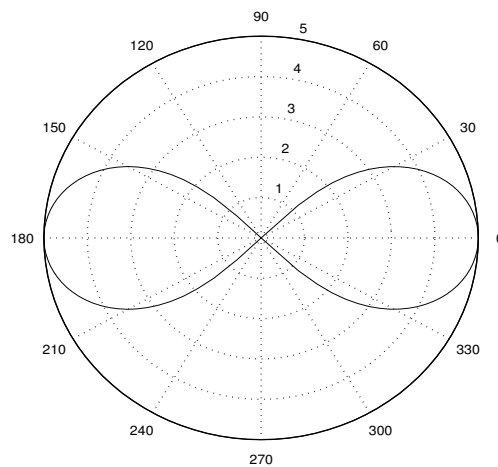

Note:

This is an example of the more general curve, $r^2 = a^2 \cos 2\theta$. It is another example of a “**lemniscate**”; but, since r^2 cannot be negative, there are no points on the curve in the intervals $\frac{\pi}{4} < \theta < \frac{3\pi}{4}$ and $\frac{5\pi}{4} < \theta < \frac{7\pi}{4}$.

9. The graph is as follows:

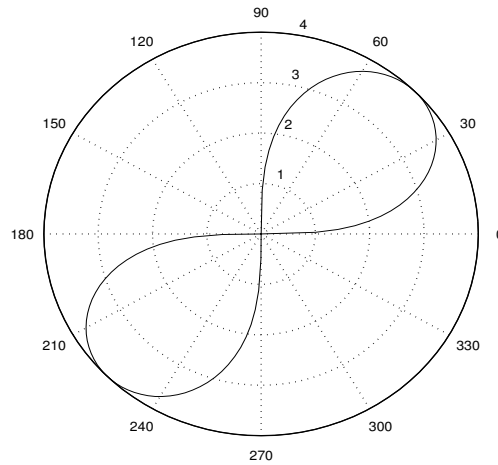

Note:

This is an example of the more general curve, $r^2 = a^2 \sin 2\theta$. It is another example of a “**lemniscate**”; but, since r^2 cannot be negative, there are no points on the curve in the intervals $\frac{\pi}{2} < \theta < \pi$ and $\frac{3\pi}{2} < \theta < 2\pi$.

10. The graph is as follows:

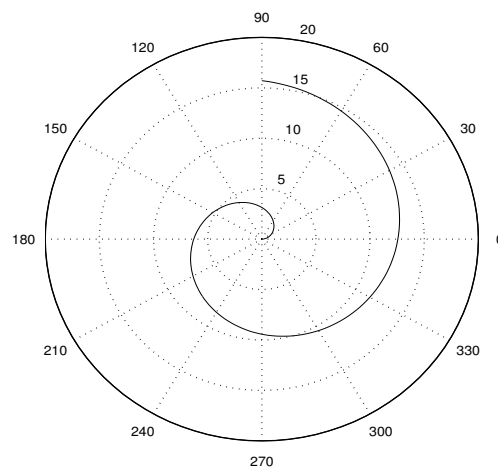

Note:

This is an example of the more general curve, $r = a\theta$, $a > 0$, which is called an “**Archimedean spiral**”.