

**“JUST THE MATHS”**

**UNIT NUMBER**

**5.2**

**GEOMETRY 2**  
**(The straight line)**

by

**A.J.Hobson**

<p><b>5.2.1 Preamble</b></p> <p><b>5.2.2 Standard equations of a straight line</b></p> <p><b>5.2.3 Perpendicular straight lines</b></p> <p><b>5.2.4 Change of origin</b></p> <p><b>5.2.5 Exercises</b></p> <p><b>5.2.6 Answers to exercises</b></p>
-----------------------------------------------------------------------------------------------------------------------------------------------------------------------------------------------------------------------------------------------------

## UNIT 5.2 - GEOMETRY 2

### THE STRAIGHT LINE

#### 5.2.1 PREAMBLE

It is not possible to give a satisfactory diagrammatic definition of a straight line since the attempt is likely to assume a knowledge of linear measurement which, itself, depends on the concept of a straight line. For example, it is no use defining a straight line as “the shortest path between two points” since the word “shortest” assumes a knowledge of linear measurement.

In fact, the straight line is defined algebraically as follows:

#### DEFINITION

A straight line is a set of points,  $(x, y)$ , satisfying an equation of the form

$$ax + by + c = 0$$

where  $a, b$  and  $c$  are constants. This equation is called a “**linear equation**” and the symbol  $(x, y)$  itself, rather than a dot on the page, represents an arbitrary point of the line.

#### 5.2.2 STANDARD EQUATIONS OF A STRAIGHT LINE

##### (a) Having a given gradient and passing through the origin

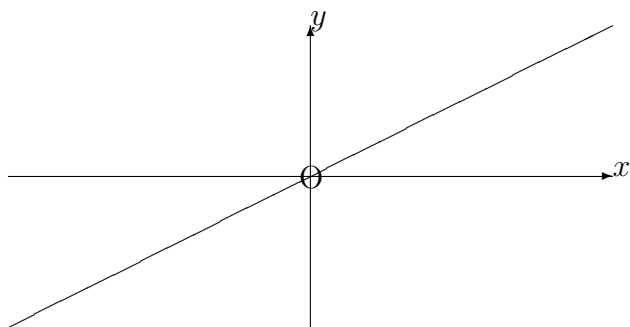

Let the gradient be  $m$ ; then, from the diagram, all points  $(x, y)$  on the straight line (**but no others**) satisfy the relationship,

$$\frac{y}{x} = m.$$

That is,

$$\boxed{y = mx}$$

which is the equation of this straight line.

**EXAMPLE**

Determine, in degrees, the angle,  $\theta$ , which the straight line,

$$\sqrt{3}y = x,$$

makes with the positive  $x$ -direction.

**Solution**

The gradient of the straight line is given by

$$\tan \theta = \frac{1}{\sqrt{3}}.$$

Hence,

$$\theta = \tan^{-1} \frac{1}{\sqrt{3}} = 30^\circ.$$

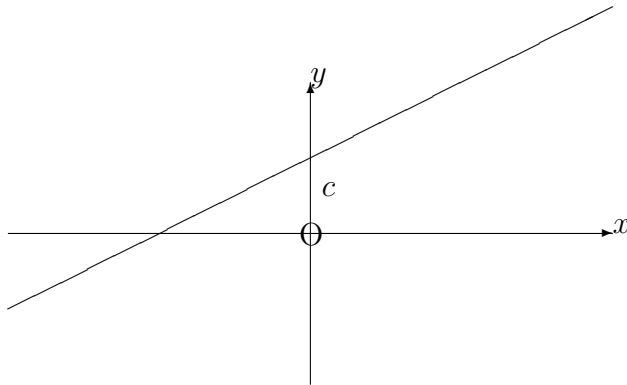
**(b) Having a given gradient, and a given intercept on the vertical axis**

Let the gradient be  $m$  and let the intercept be  $c$ ; then, in this case we can imagine that the relationship between  $x$  and  $y$  in the previous section is altered only by adding the number  $c$  to all of the  $y$  co-ordinates. Hence the equation of the straight line is

$$y = mx + c.$$

**EXAMPLE**

Determine the gradient,  $m$ , and intercept  $c$  on the  $y$ -axis of the straight line whose equation is

$$7x - 5y - 3 = 0.$$

**Solution**

On rearranging the equation, we have

$$y = \frac{7}{5}x - \frac{3}{5}.$$

Hence,

$$m = \frac{7}{5}$$

and

$$c = -\frac{3}{5}.$$

This straight line will intersect the  $y$ -axis **below** the origin because the intercept is negative.

**(c) Having a given gradient and passing through a given point**

Let the gradient be  $m$  and let the given point be  $(x_1, y_1)$ . Then,

$$y = mx + c,$$

where

$$y_1 = mx_1 + c.$$

Hence, on subtracting the second of these from the first, we obtain

$$\boxed{y - y_1 = m(x - x_1)}.$$

**EXAMPLE**

Determine the equation of the straight line having gradient  $\frac{3}{8}$  and passing through the point  $(-7, 2)$ .

**Solution**

From the formula,

$$y - 2 = \frac{3}{8}(x + 7).$$

That is

$$8y - 16 = 3x + 21,$$

giving

$$8y = 3x + 37.$$

**(d) Passing through two given points**

Let the two given points be  $(x_1, y_1)$  and  $(x_2, y_2)$ . Then, the gradient is given by

$$m = \frac{y_2 - y_1}{x_2 - x_1}.$$

Hence, from the previous section, the equation of the straight line is

$$y - y_1 = \frac{y_2 - y_1}{x_2 - x_1}(x - x_1);$$

but this is more usually written

$$\frac{y - y_1}{y_2 - y_1} = \frac{x - x_1}{x_2 - x_1}.$$

**Note:**

The same result is obtained no matter which way round the given points are taken as  $(x_1, y_1)$  and  $(x_2, y_2)$ .

**EXAMPLE**

Determine the equation of the straight line joining the two points  $(-5, 3)$  and  $(2, -7)$ , stating the values of its gradient and its intercept on the  $y$ -axis.

**Solution (Method 1).**

$$\frac{y - 3}{-7 - 3} = \frac{x + 5}{2 + 5},$$

giving

$$7(y - 3) = -10(x + 5).$$

That is,

$$10x + 7y + 29 = 0.$$

**Solution (Method 2).**

$$\frac{y + 7}{3 + 7} = \frac{x - 2}{-5 - 2},$$

giving

$$-7(y + 7) = 10(x - 2).$$

That is,

$$10x + 7y + 29 = 0,$$

as before.

By rewriting the equation of the line as

$$y = -\frac{10}{7}x - \frac{29}{7}$$

we see that the gradient is  $-\frac{10}{7}$  and the intercept on the  $y$ -axis is  $-\frac{29}{7}$ .

**(e) The parametric equations of a straight line**

In the previous section, the common value of the two fractions

$$\frac{y - y_1}{y_2 - y_1} \quad \text{and} \quad \frac{x - x_1}{x_2 - x_1}$$

is called the “**parameter**” of the point  $(x, y)$  and is usually denoted by  $t$ .

By equating each fraction separately to  $t$ , we obtain

$$x = x_1 + (x_2 - x_1)t \quad \text{and} \quad y = y_1 + (y_2 - y_1)t.$$

These are called the “**parametric equations**” of the straight line while  $(x_1, y_1)$  and  $(x_2, y_2)$  are known as the “**base points**” of the parametric representation of the line.

**Notes:**

(i) In the above parametric representation,  $(x_1, y_1)$  has parameter  $t = 0$  and  $(x_2, y_2)$  has parameter  $t = 1$ .

(ii) Other parametric representations of the same line can be found by using the given base points in the opposite order, or by using a different pair of points on the line as base points.

## EXAMPLES

1. Use parametric equations to find two other points on the line joining  $(3, -6)$  and  $(-1, 4)$ .

### Solution

One possible parametric representation of the line is

$$x = 3 - 4t \quad y = -6 + 10t.$$

To find another two points, we simply substitute any two values of  $t$  other than 0 or 1. For example, with  $t = 2$  and  $t = 3$ ,

$$x = -5, y = 14 \quad \text{and} \quad x = -9, y = 24.$$

A pair of suitable points is therefore  $(-5, 14)$  and  $(-9, 24)$ .

2. The co-ordinates,  $x$  and  $y$ , of a moving particle are given, at time  $t$ , by the equations

$$x = 3 - 4t \quad \text{and} \quad y = 5 + 2t$$

Determine the gradient of the straight line along which the particle moves.

### Solution

Eliminating  $t$ , we have

$$\frac{x - 3}{-4} = \frac{y - 5}{2}.$$

That is,

$$2(x - 3) = -4(y - 5),$$

giving

$$y = -\frac{2}{4}x + \frac{26}{4}.$$

Hence, the gradient of the line is

$$-\frac{2}{4} = -\frac{1}{2}.$$

### 5.2.3 PERPENDICULAR STRAIGHT LINES

The perpendicularity of two straight lines is not dependent on either their length or their precise position in the plane. Hence, without loss of generality, we may consider two straight line segments of equal length passing through the origin. The following diagram indicates appropriate co-ordinates and angles to demonstrate perpendicularity:

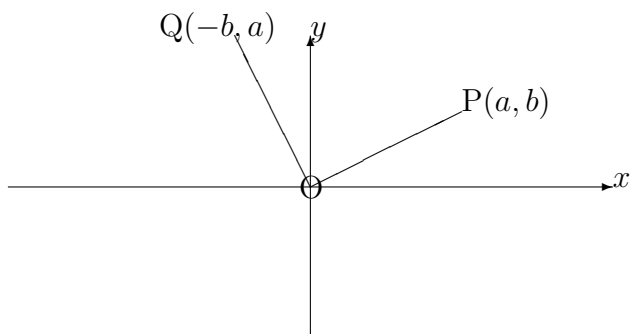

In the diagram, the gradient of  $OP = \frac{b}{a}$  and the gradient of  $OQ = \frac{a}{-b}$ .

Hence the **product of the gradients is equal to  $-1$**  or, in other words, **each gradient is minus the reciprocal of the other gradient.**

### EXAMPLE

Determine the equation of the straight line which passes through the point  $(-2, 6)$  and is perpendicular to the straight line,

$$3x + 5y + 11 = 0.$$

### Solution

The gradient of the given line is  $-\frac{3}{5}$  which implies that the gradient of a perpendicular line is  $\frac{5}{3}$ . Hence, the required line has equation

$$y - 6 = \frac{5}{3}(x + 2),$$

giving

$$3y - 18 = 5x + 10.$$

That is,

$$3y = 5x + 28.$$

### 5.2.4 CHANGE OF ORIGIN

Given a cartesian system of reference with axes  $Ox$  and  $Oy$ , it may sometimes be convenient to consider a new set of axes  $O'X$  parallel to  $Ox$  and  $O'Y$  parallel to  $Oy$  with new origin at  $O'$  whose co-ordinates are  $(h, k)$  referred to the original set of axes.

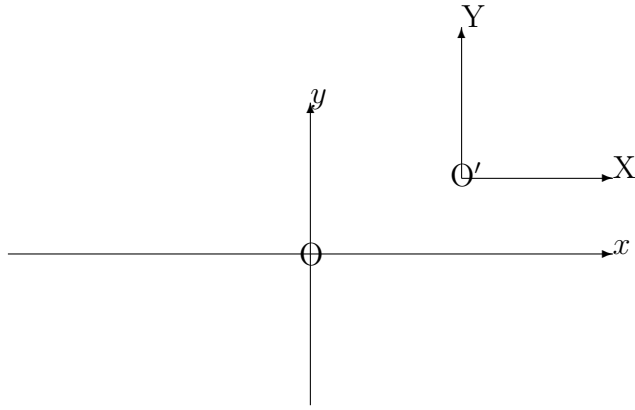

In the above diagram, everything is drawn in the first quadrant, but the relationships obtained between the old and new co-ordinates will apply in all situations. They are

$$X = x - h \quad \text{and} \quad Y = y - k$$

or

$$x = X + h \quad \text{and} \quad y = Y + k.$$

**EXAMPLE**

Given the straight line,

$$y = 3x + 11,$$

determine its equation referred to new axes with new origin at the point  $(-2, 5)$ .

**Solution**

Using

$$x = X - 2 \quad \text{and} \quad y = Y + 5,$$

we obtain

$$Y + 5 = 3(X - 2) + 11.$$

That is,

$$Y = 3X,$$

which is a straight line through the new origin with gradient 3.

**Note:**

If we had spotted that the point  $(-2, 5)$  was **on** the original line, the new line would be bound to pass through the new origin; and its gradient would not alter in the change of origin.

### 5.2.5 EXERCISES

- Determine the equations of the following straight lines:
  - having gradient 4 and intercept  $-7$  on the  $y$ -axis;
  - having gradient  $\frac{1}{3}$  and passing through the point  $(-2, 5)$ ;
  - passing through the two points  $(1, 6)$  and  $(5, 9)$ .
- Determine the equation of the straight line passing through the point  $(1, -5)$  which is perpendicular to the straight line whose cartesian equation is

$$x + 2y = 3.$$

- Given the straight line

$$y = 4x + 2,$$

referred to axes  $Ox$  and  $Oy$ , determine its equation referred to new axes  $O'X$  and  $O'Y$  with new origin at the point where  $x = 7$  and  $y = -3$  (assuming that  $Ox$  is parallel to  $O'X$  and  $Oy$  is parallel to  $O'Y$ ).

- Use the parametric equations of the straight line joining the two points  $(-3, 4)$  and  $(7, -1)$  in order to find its point of intersection with the straight line whose cartesian equation is

$$x - y + 4 = 0.$$

### 5.2.6 ANSWERS TO EXERCISES

- (a)

$$y = 4x - 7;$$

- (b)

$$3y = x + 17;$$

- (c)

$$4y = 3x + 21.$$

- 2.

$$y = 2x - 7.$$

- 3.

$$Y = 4X + 33.$$

- 4.

$$x = -3 + 10t \quad y = 4 - 5t,$$

giving the point of intersection (at  $t = \frac{1}{5}$ ) as  $(-1, 3)$ .