

“JUST THE MATHS”

UNIT NUMBER

13.8

INTEGRATION APPLICATIONS 8
(First moments of a volume)

by

A.J.Hobson

13.8.1 Introduction

**13.8.2 First moment of a volume of revolution about a plane
through the origin, perpendicular to the x -axis**

13.8.3 The centroid of a volume

13.8.4 Exercises

13.8.5 Answers to exercises

UNIT 13.8 - INTEGRATION APPLICATIONS 8

FIRST MOMENTS OF A VOLUME

13.8.1 INTRODUCTION

Suppose that R denotes a region of space (with volume V) and suppose that δV is the volume of a small element of this region.

Then the “**first moment**” of R about a fixed plane, p , is given by

$$\lim_{\delta V \rightarrow 0} \sum_R h \delta V,$$

where h is the perpendicular distance, from p , of the element with volume, δV .

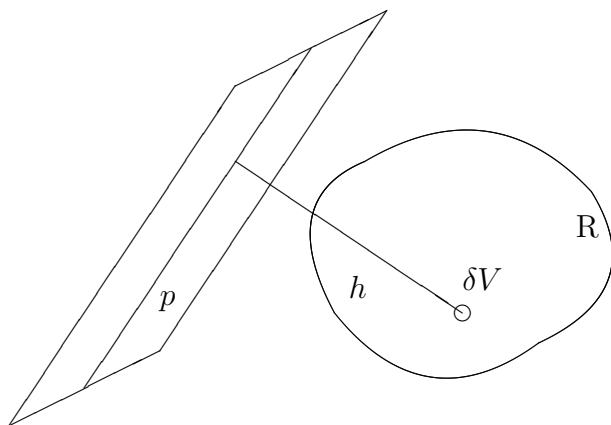

13.8.2 FIRST MOMENT OF A VOLUME OF REVOLUTION ABOUT A PLANE THROUGH THE ORIGIN, PERPENDICULAR TO THE X-AXIS.

Let us consider the volume of revolution about the x -axis of a region, in the first quadrant of the xy -plane, bounded by the x -axis, the lines $x = a$, $x = b$ and the curve whose equation is

$$y = f(x).$$

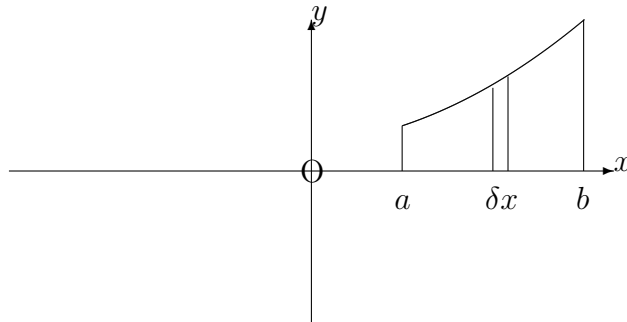

For a narrow 'strip' of width, δx , and height, y , parallel to the y -axis, the volume of revolution will be a thin disc with volume $\pi y^2 \delta x$ and all the elements of volume within it have the same perpendicular distance, x , from the plane about which moments are being taken.

Hence the first moment of this disc about the given plane is x times the volume of the disc; that is, $x(\pi y^2 \delta x)$, implying that the total first moment is given by

$$\lim_{\delta x \rightarrow 0} \sum_{x=a}^{x=b} \pi x y^2 \delta x = \int_a^b \pi x y^2 \, dx.$$

Note:

For the volume of revolution about the y -axis of a region in the first quadrant, bounded by the y -axis, the lines $y = c$, $y = d$ and the curve whose equation is

$$x = g(y),$$

we may reverse the roles of x and y so that the first moment of the volume about a plane through the origin, perpendicular to the y -axis, is given by

$$\int_c^d \pi y x^2 \, dy.$$

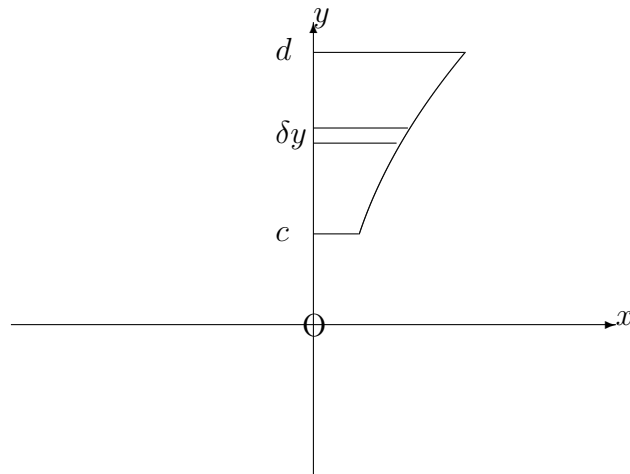

EXAMPLES

1. Determine the first moment of a solid right-circular cylinder with height, a and radius b , about one end.

Solution

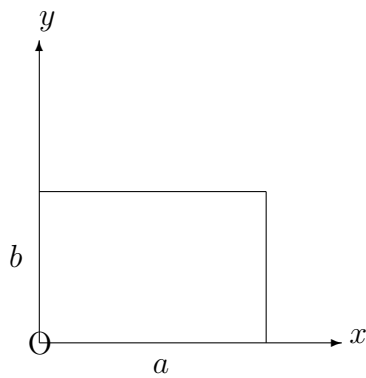

Let us consider the volume of revolution about the x -axis of the region, bounded in the first quadrant of the xy -plane, by the x -axis, the y -axis and the lines $x = a$, $y = b$.

The first moment of the volume about a plane through the origin, perpendicular to the x -axis, is given by

$$\int_0^a \pi x b^2 \, dx = \left[\frac{\pi x^2 b^2}{2} \right]_0^a = \frac{\pi a^2 b^2}{2}.$$

2. Determine the first moment of volume, about its plane base, of a solid hemisphere with radius a .

Solution

Let us consider the volume of revolution about the x -axis of the region, bounded in the first quadrant, by the x -axis, y -axis and the circle whose equation is

$$x^2 + y^2 = a^2.$$

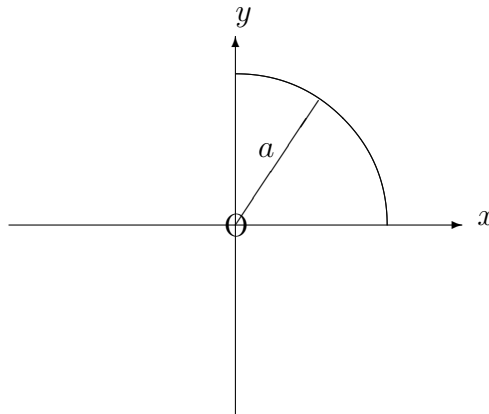

The first moment of the volume about a plane through the origin, perpendicular to the x -axis is given by

$$\int_0^a \pi x (a^2 - x^2) \, dx = \left[\pi \left(\frac{a^2 x^2}{2} - \frac{x^4}{4} \right) \right]_0^a = \pi \left(\frac{a^4}{2} - \frac{a^4}{4} \right) = \frac{\pi a^4}{4}.$$

Note:

The symmetry of the solid figures in the above two examples shows that their first moments about a plane through the origin, perpendicular to the y -axis would be zero. This is because, for each $y\delta V$ in the calculation of the total first moment, there will be a corresponding $-y\delta V$.

In much the same way, the first moments of volume about the xy -plane (or indeed any plane of symmetry) would also be zero.

13.8.3 THE CENTROID OF A VOLUME

Suppose R denotes a volume of revolution about the x -axis of a region of the xy -plane, bounded by the x -axis, the lines $x = a$, $x = b$ and the curve whose equation is

$$y = f(x).$$

Having calculated the first moment of R about a plane through the origin, perpendicular to the x -axis (assuming that this is not a plane of symmetry), it is possible to determine a point, $(\bar{x}, 0)$, on the x -axis with the property that the first moment is given by $V\bar{x}$, where V is the total volume of revolution about the x -axis.

The point is called the “**centroid**” or the “**geometric centre**” of the volume, and \bar{x} is given by

$$\bar{x} = \frac{\int_a^b \pi xy^2 dx}{\int_a^b \pi y^2 dx} = \frac{\int_a^b xy^2 dx}{\int_a^b y^2 dx}.$$

Notes:

(i) The centroid effectively tries to concentrate the whole volume at a single point for the purposes of considering first moments. It will always lie on the line of intersection of any two planes of symmetry.

(ii) In practice, the centroid corresponds to the position of the centre of mass for a solid with uniform density, whose shape is that of the volume of revolution which we have been considering.

(iii) For a volume of revolution about the y -axis, from $y = c$ to $y = d$, the centroid will lie on the y -axis, and its distance, \bar{y} , from the origin will be given by

$$\bar{y} = \frac{\int_c^d \pi yx^2 dy}{\int_c^d \pi x^2 dy} = \frac{\int_c^d yx^2 dy}{\int_c^d x^2 dy}.$$

(iv) The first moment of a volume about a plane through its centroid will, by definition, be zero. In particular, if we take the plane through the y -axis, perpendicular to the x -axis to be parallel to the plane through the centroid, with x as the perpendicular distance from an element, δV , to the plane through the y -axis, the first moment about the plane through the centroid will be

$$\sum_{\mathbf{R}} (x - \bar{x})\delta V = \sum_{\mathbf{R}} x\delta V - \bar{x} \sum_{\mathbf{R}} \delta V = V\bar{x} - V\bar{x} = 0.$$

EXAMPLES

1. Determine the position of the centroid of a solid right-circular cylinder with height, a , and radius, b .

Solution

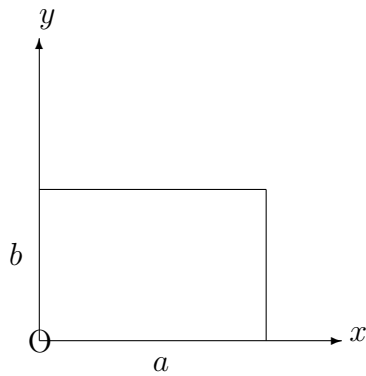

Using Example 1 in Section 13.8.2, the centroid will lie on the x -axis and the first moment about a plane through the origin, perpendicular to the x -axis is $\frac{\pi a^2 b^2}{2}$.

Also, the volume is $\pi b^2 a$.

Hence,

$$\bar{x} = \frac{\frac{\pi a^2 b^2}{2}}{\pi b^2 a} = \frac{a}{2},$$

as we would expect for a cylinder.

2. Determine the position of the centroid of a solid hemisphere with base-radius, a .

Solution

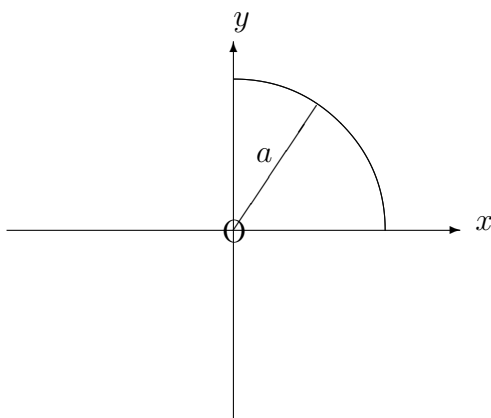

Let us consider the volume of revolution about the x -axis of the region bounded in the first quadrant by the x -axis, the y -axis and the circle whose equation is

$$x^2 + y^2 = a^2$$

From Example 2 in Section 13.8.2, the centroid will lie on the x -axis and the first moment of volume about a plane through the origin, perpendicular to the x -axis is $\frac{\pi a^4}{4}$.

Also, the volume of the hemisphere is $\frac{2}{3}\pi a^3$ and so,

$$\bar{x} = \frac{\frac{2}{3}\pi a^3}{\frac{\pi a^4}{4}} = \frac{3a}{8}.$$

3. Determine the position of the centroid of the volume of revolution about the y -axis of region bounded in the first quadrant by the x -axis, the y -axis and the curve whose equation is

$$y = 1 - x^2.$$

Solution

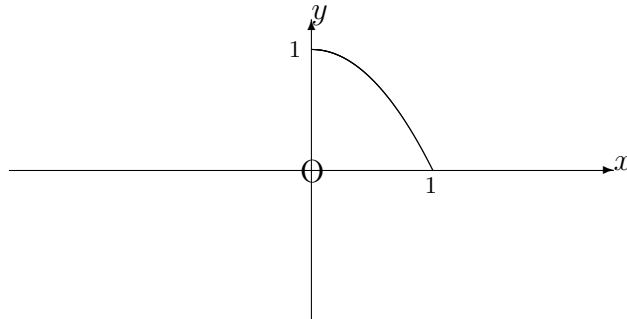

Firstly, by symmetry, the centroid will lie on the y -axis.

Secondly, the first moment about a plane through the origin, perpendicular to the y -axis is given by

$$\int_0^1 \pi y(1-y) dy = \pi \left[\frac{y^2}{2} - \frac{y^3}{3} \right]_0^1 = \frac{\pi}{6}.$$

Thirdly, the volume is given by

$$\int_0^1 \pi(1-y) dy = \left[y - \frac{y^2}{2} \right]_0^1 = \frac{\pi}{2}.$$

Hence,

$$\bar{y} = \frac{\pi}{6} \div \frac{\pi}{2} = \frac{1}{3}.$$

4. Determine the position of the centroid of the volume of revolution about the x -axis of the region, bounded in the first quadrant by the x -axis, the lines $x = 1$, $x = 2$ and the curve whose equation is

$$y = e^x.$$

Solution

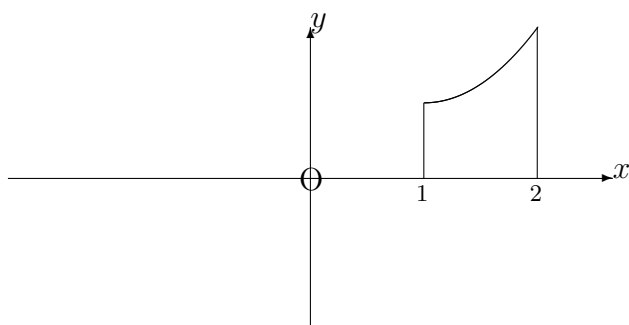

Firstly, by symmetry, the centroid will lie on the x axis.

Secondly, the First Moment about a plane through the origin, perpendicular to the x -axis is given by

$$\int_1^2 \pi x e^{2x} dx = \pi \left[\frac{x e^{2x}}{2} - \frac{e^{2x}}{4} \right]_1^2 \simeq 122.84,$$

using integration by parts.

The volume is given by

$$\int_1^2 \pi e^{2x} dx = \pi \left[\frac{e^{2x}}{2} \right]_1^2 \simeq 74.15$$

Hence,

$$\bar{x} \simeq 122.84 \div 74.15 \simeq 1.66$$

13.8.4 EXERCISES

1. Determine the position of the centroid of the volume obtained when each of the following regions of the xy -plane is rotated through 2π radians about the x -axis:

- (a) Bounded in the first quadrant by the x -axis, the line $x = 1$ and the quarter-circle represented by

$$(x - 1)^2 + y^2 = 4, \quad x > 1, y > 0;$$

- (b) Bounded in the first quadrant by the x -axis, the y -axis and the curve whose equation is

$$y = 1 - 2x^2;$$

- (c) Bounded in the first quadrant by the x -axis, the y -axis, the line $x = \frac{\pi}{2}$ and the curve whose equation is

$$y = \sin x;$$

- (d) Bounded in the first quadrant by the x -axis, the y -axis, the line $x = 1$ and the curve whose equation is

$$y = \sqrt{x}e^{-x}.$$

2. A solid right-circular cone, whose vertex is at the origin, has, for its central axis, the part of the y -axis between $y = 0$ and $y = h$. Determine the position of the centroid of the cone.

13.8.5 ANSWERS TO EXERCISES

1. (a)

$$\bar{x} = 1.75;$$

- (b)

$$\bar{x} \simeq 0.22;$$

- (c)

$$\bar{x} \simeq 1.10;$$

- (d)

$$\bar{x} \simeq 0.36$$

- 2.

$$\bar{y} = \frac{3h}{4}.$$