

“JUST THE MATHS”

UNIT NUMBER

13.3

INTEGRATION APPLICATIONS 3
(Volumes of revolution)

by

A.J.Hobson

13.3.1 Volumes of revolution about the x -axis

13.3.2 Volumes of revolution about the y -axis

13.3.3 Exercises

13.3.4 Answers to exercises

UNIT 13.3 - INTEGRATION APPLICATIONS 3

VOLUMES OF REVOLUTION

13.3.1 VOLUMES OF REVOLUTION ABOUT THE X-AXIS

Suppose that the area between a curve whose equation is

$$y = f(x)$$

and the x -axis, from $x = a$ to $x = b$, lies wholly above the x -axis; suppose, also, that this area is rotated through 2π radians about the x -axis. Then a solid figure is obtained whose volume may be determined as an application of definite integration.

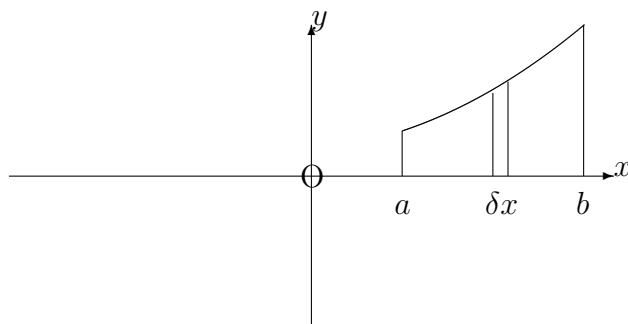

When a narrow strip of width, δx , and height, y , is rotated through 2π radians about the x -axis, we obtain a disc whose volume, δV , is given approximately by

$$\delta V \simeq \pi y^2 \delta x.$$

Thus, the total volume, V , obtained is given by

$$V = \lim_{\delta x \rightarrow 0} \sum_{x=a}^{x=b} \pi y^2 \delta x.$$

That is,

$$V = \int_a^b \pi y^2 dx.$$

EXAMPLE

Determine the volume obtained when the area, bounded in the first quadrant by the x -axis, the y -axis, the straight line, $x = 2$, and the parabola, $y^2 = 8x$, is rotated through 2π radians about the x -axis.

Solution

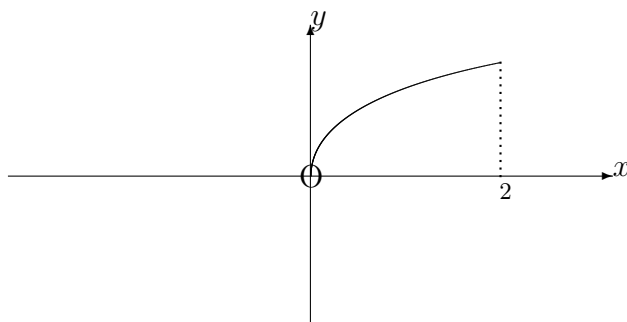

$$V = \int_0^2 \pi \times 8x \, dx = [4\pi x^2]_0^2 = 16\pi.$$

13.3.2 VOLUMES OF REVOLUTION ABOUT THE Y-AXIS

First we consider the same diagram as in the previous section:

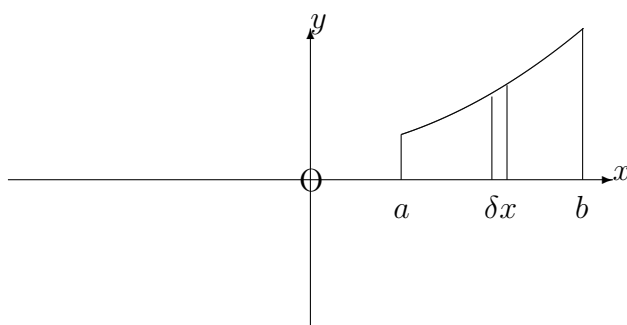

This time, if the narrow strip of width, δx , is rotated through 2π radians about the y -axis,

we obtain, approximately, a cylindrical shell of internal radius, x , external radius, $x + \delta x$ and height, y .

The volume, δV , of the shell is thus given by

$$\delta V \simeq 2\pi xy\delta x.$$

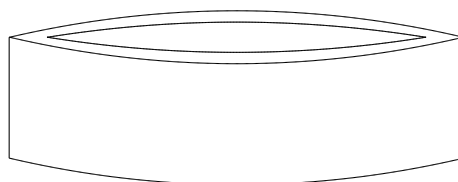

The total volume is given by

$$V = \lim_{\delta x \rightarrow 0} \sum_{x=a}^{x=b} 2\pi xy\delta x.$$

That is,

$$V = \int_a^b 2\pi xy \, dx.$$

EXAMPLE

Determine the volume obtained when the area, bounded in the first quadrant by the x -axis, the y -axis, the straight line $x = 2$ and the parabola $y^2 = 8x$ is rotated through 2π radians about the y -axis.

Solution

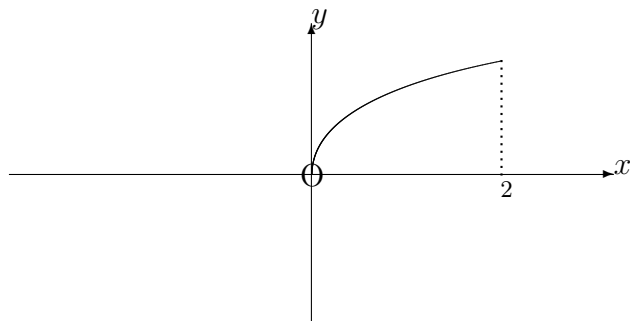

$$V = \int_0^2 2\pi x \times \sqrt{8x} \, dx.$$

In other words,

$$V = \pi 4\sqrt{2} \int_0^2 x^{\frac{3}{2}} dx = \pi 4\sqrt{2} \left[\frac{2x^{\frac{5}{2}}}{5} \right]_0^2 = \frac{64\pi}{5}.$$

Note:

It may be required to find the volume of revolution about the y -axis of an area which is contained between a curve and the y -axis from $y = c$ to $y = d$.

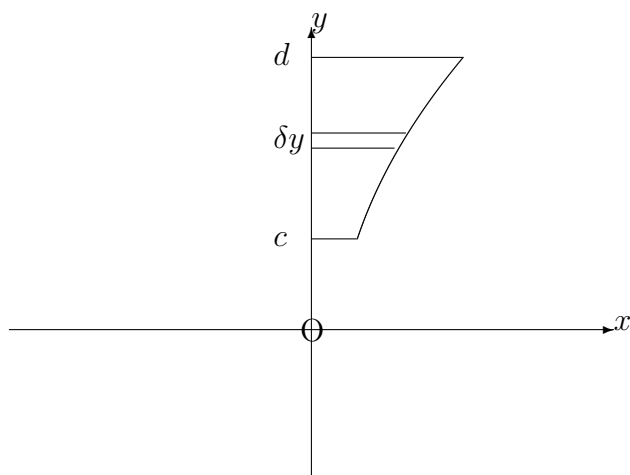

But here we simply interchange the roles of x and y in the original formula for rotation about the x -axis; that is

$$V = \int_c^d \pi x^2 \, dy.$$

Similarly, the volume of rotation of the above area about the x -axis is given by

$$V = \int_c^d 2\pi yx \, dy.$$

13.3.3 EXERCISES

1. By using a straight line through the origin, obtain a formula for the volume, V , of a solid right-circular cone with height, h , and base radius, r .
2. Determine the volume obtained when the segment straight line

$$y = 5 - 4x,$$

lying between $x = 0$ and $x = 1$, is rotated through 2π radians about (a) the x -axis and (b) the y -axis.

3. Determine the volume obtained when the part of the curve

$$y = \cos 3x,$$

lying between $x = \frac{\pi}{6}$ and $x = \frac{\pi}{3}$, is rotated through 2π radians about the x -axis.

4. Determine the volume obtained when the part of the curve

$$y = \frac{1}{x\sqrt{2+x}},$$

lying between $x = 2$ and $x = 7$, is rotated through 2π radians about the x -axis.

5. Determine the volume obtained when the part of the curve

$$y = \frac{1}{(x-1)(x-5)},$$

lying between $x = 6$ and $x = 8$, is rotated through 2π radians about the y -axis.

6. Determine the volume obtained when the part of the curve

$$x = ye^{-y},$$

lying between $y = 0$ and $y = 1$, is rotated through 2π radians about the y -axis.

7. Determine the volume obtained when the part of the curve

$$y = \sin 2x,$$

lying between $x = \frac{\pi}{4}$ and $x = \frac{\pi}{2}$, is rotated through 2π radians about the y -axis.

8. Determine the volume obtained when the part of the curve

$$y = x(1-x^3)^{\frac{1}{4}},$$

lying between $x = 0$ and $x = 1$, is rotated through 2π radians about the x -axis.

9. Determine the volume obtained when the part of the curve

$$x = (4-y^2)^2,$$

lying between $y = 1$ and $y = 2$, is rotated through 2π radians about the x -axis.

10. Determine the volume obtained when the part of the curve

$$y = x \sec(x^3),$$

lying between $x = 0$ and $x = 0.5$, is rotated through 2π radians about the x -axis.

11. Determine the volume obtained when the part of the curve

$$y = \frac{1}{x^2-1},$$

lying between $x = 2$ and $x = 3$ is rotated through 2π radians about the y -axis.

13.3.4 ANSWERS TO EXERCISES

1.

$$V = \frac{1}{3}\pi r^2 h.$$

2.

$$(a) \frac{\pi}{3} \simeq 1.047 \quad (b) \frac{7\pi}{3} \simeq 7.330$$

3.

$$\frac{\pi^2}{12} \simeq 0.822$$

4.

0.214 approximately.

5.

8.010 approximately.

6.

0.254 approximately.

7.

3.364 approximately.

8.

$$\frac{2\pi}{9} \simeq 0.698$$

9.

$$9\pi \simeq 28.274$$

10.

0.132 approximately.

11.

3.081 approximately.